



## Terex Stinger 61000 Boom Truck Crane

### FEATURES

- **60,000 lbs. (27 211 kg) maximum lifting capacity**
- **110 ft. (33.5 m) maximum sheave height**
- **163 ft. (49.6 m) maximum sheave height with 55 ft. (16.8 m) jib**
- 100 ft. (30.5 m) fully proportional four-section telescopic “keel” boom
- Choice of three configurations – behind cab (with either 180° or 360° work area), rear mount or riding seat
- Easy-to-install optional 55 ft. (16.8 m) jib, man baskets or work platform increase job capabilities
- Exclusive color coded boom and load charts
- Electronic load moment indicator and anti-two-block device standard
- 2- speed winch has 15,000 lb. (6804 kg) maximum line pull, 101 fpm (31 mpm) line speed
- Externally located planetary rotation drive for easy accessibility for maintenance
- Dual operator stations with direct mechanically controlled hydraulic system (single station on RS model)
- 90 gal. (340 l) hydraulic tank
- Terex Support Plus product service

# STINGER 60100 LOAD RATINGS



**CAUTION:** Do not use this specification sheet as a load rating chart. The format of data is not consistent with the machine chart and may be subject to change.

## Load Ratings (Pounds) for 360° Full Capacity Work Area with Outriggers Extended and Optional Front Stabilizer

OPER. RADIUS (FT)	BOOM LENGTH											
	30.5 FT		44 FT		58 FT		72 FT		86 FT		100 FT	
	LOADED BOOM ANGLE (DEG)	LOAD RATING (LB)	LOADED BOOM ANGLE (DEG)	LOAD RATING (LB)	LOADED BOOM ANGLE (DEG)	LOAD RATING (LB)	LOADED BOOM ANGLE (DEG)	LOAD RATING (LB)	LOADED BOOM ANGLE (DEG)	LOAD RATING (LB)	LOADED BOOM ANGLE (DEG)	LOAD RATING (LB)
5	79	60,000										
8	73	45,400										
10	69	38,800	76	26,500								
12	65	33,800	73	26,500	78	25,600						
15	58	28,600	69	26,500	75	23,500	79	19,800				
20	46	22,500	62	20,400	69	19,700	75	18,000	77	15,000		
25	30	17,050	54	15,900	64	15,900	70	14,800	74	12,700	77	12,300
30			45	12,500	58	12,800	66	12,800	71	11,750	74	10,700
35			35	10,200	52	10,400	62	10,700	67	10,150	71	9,300
40			19	8,100	45	8,650	57	8,900	63	9,000	68	8,000
45					38	7,250	52	7,450	59	7,550	64	7,000
50					28	6,000	46	6,250	55	6,400	61	5,750
55					12	4,600	40	5,350	51	5,450	58	4,650
60							33	4,300	46	4,700	54	3,700
65							24	3,700	41	4,000	50	3,100
70									35	3,450	48	2,500
75									28	2,400	42	2,000
80									19	2,300	37	1,650
85											32	1,550
90											25	1,200
95											16	900

**BT & RM Models**

NOTE: RATINGS ABOVE THE HEAVY LINE ARE BASED ON STRUCTURAL COMPETENCE AND NOT ON MACHINE STABILITY.

OPER. RADIUS (FT)	BOOM LENGTH											
	30.5 FT		44 FT		58 FT		72 FT		86 FT		100 FT	
	LOADED BOOM ANGLE (DEG)	LOAD RATING (LB)	LOADED BOOM ANGLE (DEG)	LOAD RATING (LB)	LOADED BOOM ANGLE (DEG)	LOAD RATING (LB)	LOADED BOOM ANGLE (DEG)	LOAD RATING (LB)	LOADED BOOM ANGLE (DEG)	LOAD RATING (LB)	LOADED BOOM ANGLE (DEG)	LOAD RATING (LB)
5	79	60,000										
8	72	43,100										
10	67	36,550	75	26,500								
12	63	31,800	72	26,500	78	25,250						
15	55	27,050	68	25,475	74	23,025	79	19,675				
20	40	20,600	60	19,400	68	19,050	74	17,600	77	14,750		
25			52	14,975	63	15,250	69	14,450	74	12,500	77	12,125
30			42	11,775	57	12,200	65	12,450	70	11,500	74	10,500
35			32	9,375	50	9,875	61	10,250	66	9,900	70	9,100
40					43	8,175	54	8,425	62	8,650	67	7,825
45					35	7,775	50	7,050	58	7,200	63	6,725
50					22	5,400	44	5,950	54	6,100	60	5,500
55							38	4,975	50	5,200	57	4,400
60							30	3,950	44	4,450	53	3,525
65							20	3,550	39	3,800	49	2,900
70									32	3,000	45	2,325
75									24	2,300	40	1,875
80											35	1,550
85											29	1,325
90											20	1,075

**RS Model**

NOTE: RATINGS ABOVE THE HEAVY LINE ARE BASED ON STRUCTURAL COMPETENCE AND NOT ON MACHINE STABILITY.

### Stowed Jib Deductions (Pounds)

900	700	500	400	335	300
-----	-----	-----	-----	-----	-----

## Range Diagram (30.5' – 100' boom) BT model shown. Range Diagrams for RM and RS models are similar.

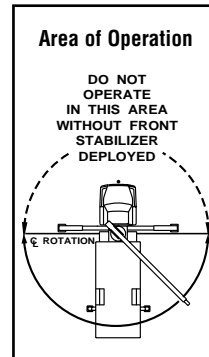
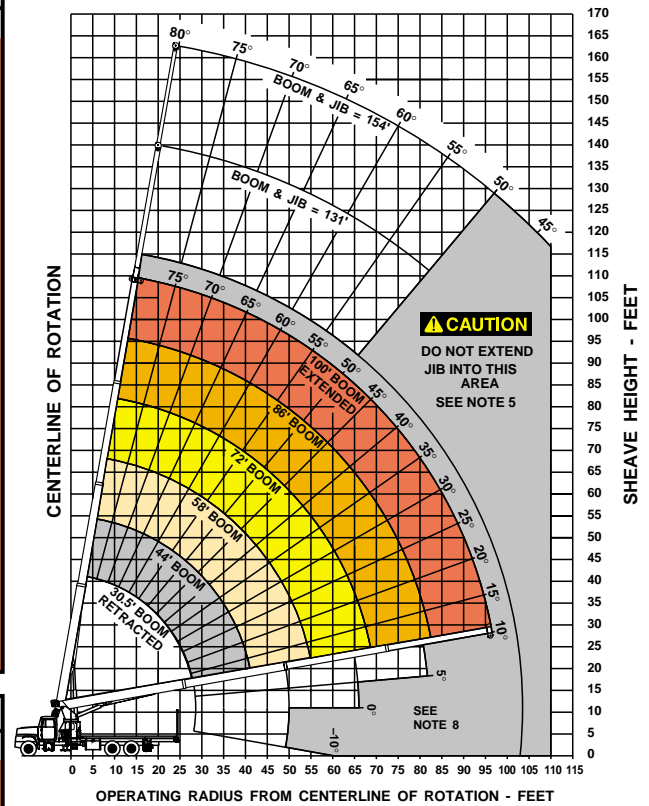

**Deductions from Rated Loads for Handling Devices**

OVERHAUL BALL:	200 lbs.
1 SHEAVE LOAD BLOCK:	225-550 lbs.
2 SHEAVE LOAD BLOCK:	300-650 lbs.

**JIB CAPACITIES FOR ALL BOOM LENGTHS**  
VERIFY OPERATIONAL MODE SETTING ON MG585 DISPLAY BEFORE LIFTING WITH JIB

Loaded Boom Angle	50°	55°	60°	65°	70°	75°	78°	80°
Retracted 30.5 ft. Jib	800	1400	2300	3300	4000	5300	6000	6450
Extended 55 ft. Jib	700	1050	1700	2300	3000	3500	3500	3500

## General Notes

- The operator must read and understand the Owner's Manual before operating this crane.
- Positioning or operation of crane beyond areas shown on this chart is not intended or approved except where specified in Owner's Manual.
- Loaded boom angles at specified boom lengths give only an approximation of the operating radius. The boom angle before loading should be greater to account for deflections. Do not exceed the operating radius for rated loads.
- Use rating of next longer boom for boom lengths not shown. Use rating of next greater radius for load radii not shown.
- Boom must be fully retracted when jib is erected before lowering below minimum angle. Retracted jib has no lifting capacity below a 50° boom angle.
- Use rating of next lower boom angle for boom angles not shown on jib load rating chart.
- Lifting off the main boom point while the swing around jib is erected is not intended or approved.
- Do not lower boom into this area, as hydraulic pressure will not allow raising the boom without retracting boom first.
- Crane load ratings on outriggers are based on freely suspended loads with the machine leveled and standing on a firm uniform supporting surface. No attempt shall be made to move a load horizontally on the ground in any direction.
- Practical working loads depend on supporting surface, wind and other factors affecting stability such as hazardous surroundings, experience of personnel, and proper handling, must all be taken into account by the operator.
- The maximum load which may be telescoped is limited by hydraulic pressure, boom angle, and boom lubrication. It is safe to attempt to telescope any load within the limits of the load rating chart.

### INFORMATION

- Deductions must be made from rated loads for stowed jib, optional attachments, hooks and loadblocks (see deduction chart). Weights of slings and other load handling devices shall be considered a part of the load.

- Crane load ratings with outriggers are based on outriggers and stabilizers extended and set with all load removed from the carrier wheels.
  - Load ratings do not exceed 85% of tipping load.
- DEFINITIONS**
- Operating radius is the horizontal distance from the axis of rotation to the center of the vertical hoist line or load hook with load suspended.
  - Loaded boom angle as shown in the Load Ratings Chart is the included angle between the horizontal and longitudinal axes of the boom base after lifting rated load at rated radius.

# WINCH DATA

		1 Part Line	2 Part Line	3 Part Line	4 Part Line	5 Part Line
<b>Winch</b>	<b>Cable Supplied</b>	<b>Lift and Speed</b>	<b>Lift and Speed</b>	<b>Lift and Speed</b>	<b>Lift and Speed</b>	<b>Lift and Speed</b>
<b>Standard Stationary Winch</b>	5/8" Diam. IWRC XXIP	12,971 lb. 75.6 fpm*	25,942 lb. 37.8 fpm*	38,913 lb. 25.2 fpm*	51,844 lb. 18.9 fpm*	60,000 lb. 15.1 fpm*
	5/8" Diam. Rotation Resistant	9080 lb. 75.6 fpm*	18,160 lb. 37.8 fpm*	27,240 lb. 25.2 fpm*	36,320 lb. 18.9 fpm*	45,400 lb. 15.1 fpm*

Block Type	Rating
Overhaul Ball	6.5 ton (5.9 mt)
1 Sheave Block	17 ton (15.4 mt)
2 Sheave Block	30 ton (27.2 mt)

## CAUTION

Overload and anti-two-block systems must be in good operating condition before operating crane. Refer to Owners Manual. Keep at least 3 wraps of loadline on drum at all times. Use only 5/8" diameter cable with 45,400 lb. breaking strength on this machine.

\*First layer speed. For fourth layer speed, multiply \*value by 1.33, for burst speed, multiply by 1.7.

# MOUNTING CONFIGURATIONS

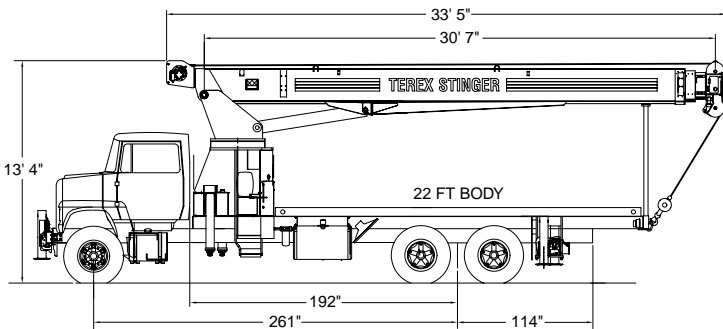

## Behind Cab (BT) Mounting Configuration

Gross Vehicle Weight Rating	52,000 lbs. (23 587 kg)
Front Axle Weight Rating	18,000 lbs. (8165 kg)
Rear Axle Weight Rating	34,000 lbs. (15 422 kg)
Wheelbase	261 in. (6629 mm)
Cab to Axle	192 in. (4877 mm)
Afterframe	114 in. (2896 mm)
Transmission	Heavy-Duty (Neutral lock-up required for automatic transmission)
Electrical System	Heavy-Duty
Cooling System	Heavy-Duty
Frame Section Modulus	30.0 in <sup>3</sup> (491 cm <sup>3</sup> )
RBM Per Frame Rail	3,300,000 in. lb. (38 020 m. kg)

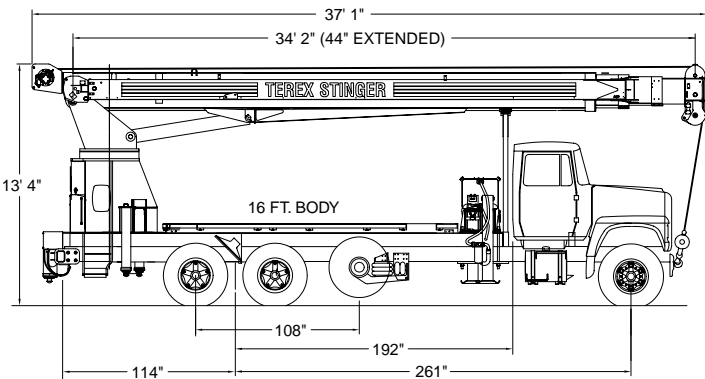

## Rear Mount (RM) Mounting Configuration

Gross Vehicle Weight Rating	60,500 lbs. (27 443 kg)
Front Axle Weight Rating	18,000 lbs. (8165 kg)
Rear Axle Weight Rating	42,500 lbs. (19 278 kg)
Wheelbase	261 in. (6629 mm)
Cab to Axle	192 in. (4877 mm)
Afterframe	114 in. (2896 mm)
Transmission	Heavy-Duty (Neutral lock-up required for automatic transmission)
Electrical System	Heavy-Duty
Cooling System	Heavy-Duty
Frame Section Modulus	40.0 in <sup>3</sup> (655 cm <sup>3</sup> )
RBM Per Frame Rail	4,440,000 in. lb. (50 694 m. kg)

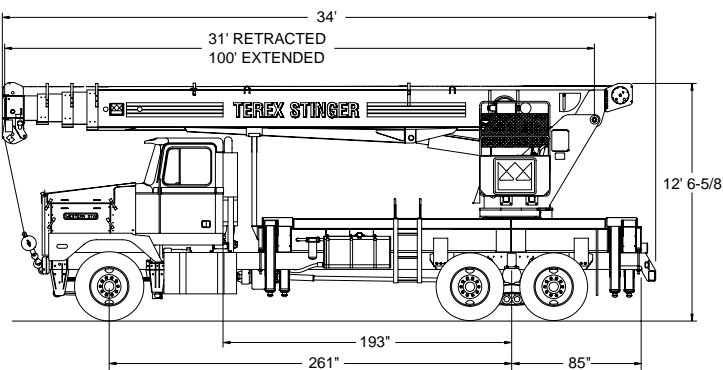

## Riding Seat (RS) Mounting Configuration

Gross Vehicle Weight Rating	60,500 lbs. (27 443 kg)
Front Axle Weight Rating	18,000 lbs. (8165 kg)
Rear Axle Weight Rating	42,500 lbs. (19 278 kg)
Wheelbase	261 in. (6629 mm)
Cab to Axle	192 in. (4877 mm)
Afterframe	85 in. (2159 mm)
Transmission	Heavy-Duty (Neutral lock-up required for automatic transmission)
Electrical System	Heavy-Duty
Cooling System	Heavy-Duty
Frame Section Modulus	30.0 in <sup>3</sup> (491 cm <sup>3</sup> )
RBM Per Frame Rail	3,300,000 in. lb. (38 020 m. kg)

**Notes:** Some standard features for the optional mounting configurations will vary. Consult your Terex Cranes dealer or factory for chassis and mounting requirements.

# TEREX STINGER 60100

## Boom Truck Crane

### SPECIFICATIONS

#### Boom

100 ft. (30.5 m) four section full power mechanically synchronized boom. Patented keel boom design utilizes a keel-shaped baseplate combined with a deep, four plate boom section to optimize strength / rigidity-to-weight ratio. Exclusive, patented color-coded boom and load charts allow the operator to easily and quickly determine boom extension, boom angle and load capacity. Maximum sheave height with four section 100 ft. (30.5 m) boom is 110 ft. (33.5 m). Maximum sheave height with optional two-stage 55 ft. (16.76 m) jib is 165 ft. (50.3 m).

#### Winch

Hydraulic winch with gear motor and planetary reduction gearing provides 2-speed "burst of speed" operation. First layer rope pull is 15,000 lbs. (6804 kg). Wire rope size is 5/8" (16 mm) with 45,400 lbs. (20 593 kg) breaking strength.

#### Operating Speeds

Main frame / turret assembly planetary rotation provides 180° rotation (370° with optional front bumper outrigger). Swing rotation is 56 seconds. Boom up/down is 42/32 seconds and boom extend/retract is 108/50 seconds.

#### Hydraulics

Three section pump allows the operator to perform simultaneous crane operations (winch, boom and swing). Capacities are 36, 20 and 11 gpm (136.3, 75.7 and 41.6 lpm). Combined system capacity is 67 gpm (253.6 lpm).

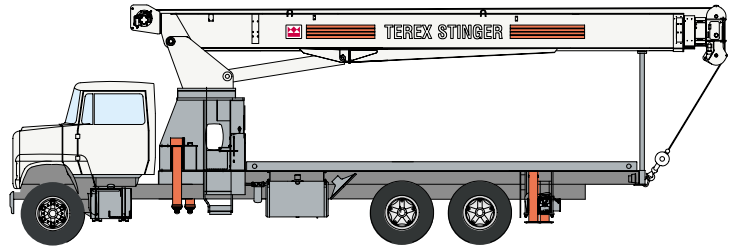

#### Controls

Fully proportional, excellent metering characteristics for precise boom movements. Independent outrigger controls allows the crane to be stable and level in rigorous working conditions. Load Moment Indicating System has audio alarm and functional shut down when operator encounters an overload situation.

#### Outriggers

Front and rear outriggers are heavy-duty, out and down type. Front spread is 24 ft. 6 in. (7.47 m) for exceptional stability. Rear spread is 17' 6" (5.33 m).

#### Subframe

Cross-braced, closed-box style subframe yields greater strength and rigidity. Wheel base for standard truck crane mounting configuration is 261 in. (6.63 m).

### OPTIONS AND ACCESSORIES

Terex Stinger offers a wide range of options and accessories to customize your truck crane to your exact needs.

These include:

- Single and two-stage jibs
- Multi-part load blocks
- Auxiliary winch
- Spin-resistant load line
- Wood, steel or extra heavy duty steel flatbeds
- Radio remote controls
- One-man or two-man baskets
- Self-leveling work platform
- Winch drum tensioner
- Continuous rotation (standard on RS model)
- Oil cooler
- Rear bumper
- Single front bumper outrigger (required for continuous or 370° rotation on BT or RM models)
- Hydraulic hose reel
- Hydraulic auxiliary tool circuit
- Removeable cab (RS model only)

For more information, product demonstration, or details on purchase, lease and rental plans, please contact your local Terex Cranes dealer.

We reserve the right to amend these specifications at any time without notice. The only warranty applicable is our standard written warranty applicable to the particular product and sale. We make no other warranty, expressed or implied.

 **TEREX CRANES**

550 Old Highway 56  
Olathe, KS 66061-4640 USA  
(913) 782-1200 • FAX: (913) 782-1625  
E-mail: olathe@terexlifting.com

[www.terexlift.com](http://www.terexlift.com)