

Shuttlelift Carrydeck Crane 5560B - Specs

5560B

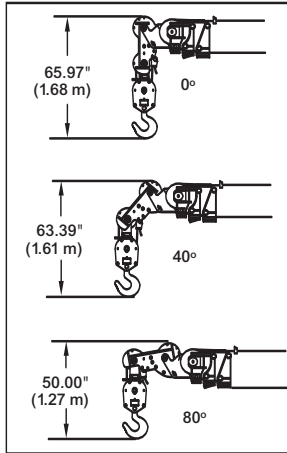

Dimensions are with the boom horizontal and the anti-two block bottomed.

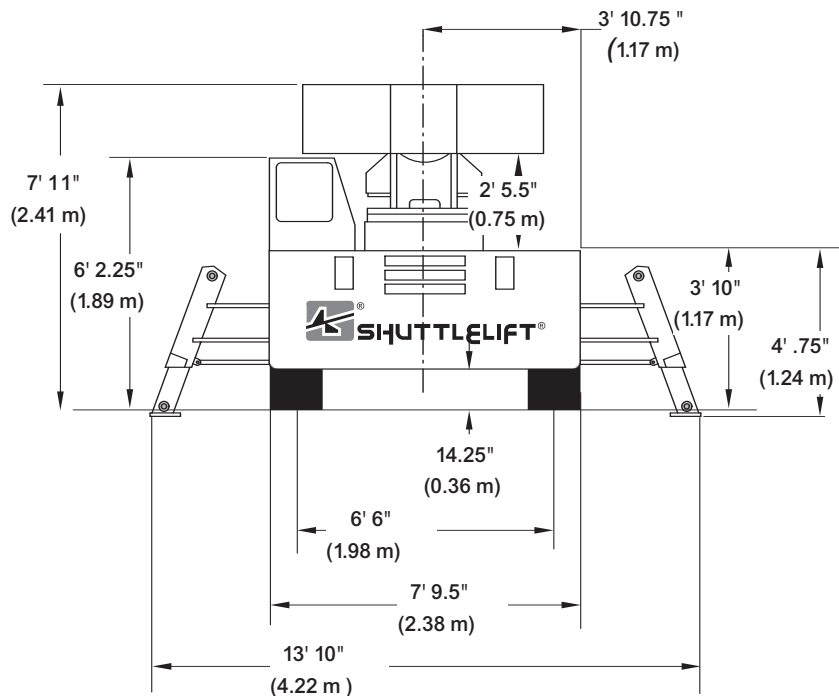
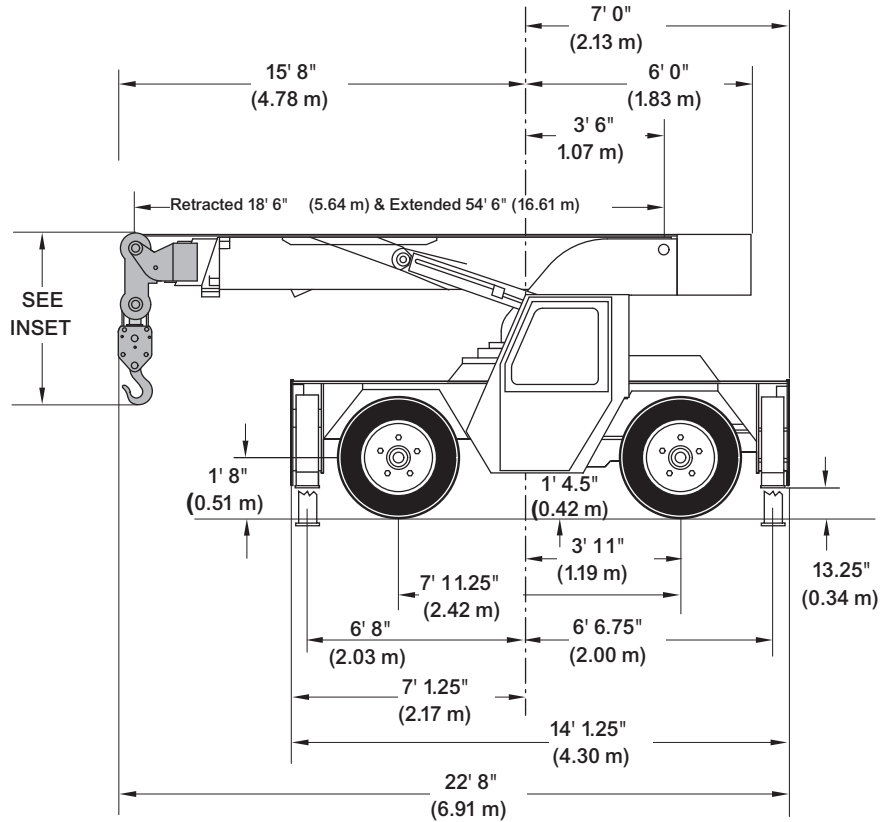

410 Stevenson Dr • Bolingbrook, IL 60440 • 630-972-9199
 16675 Van Dam Rd • South Holland, IL 60473 • 219-972-9199

www.stevensoncrane.com

Shuttlelift Carrydeck Crane 5560B - Specs

5560B

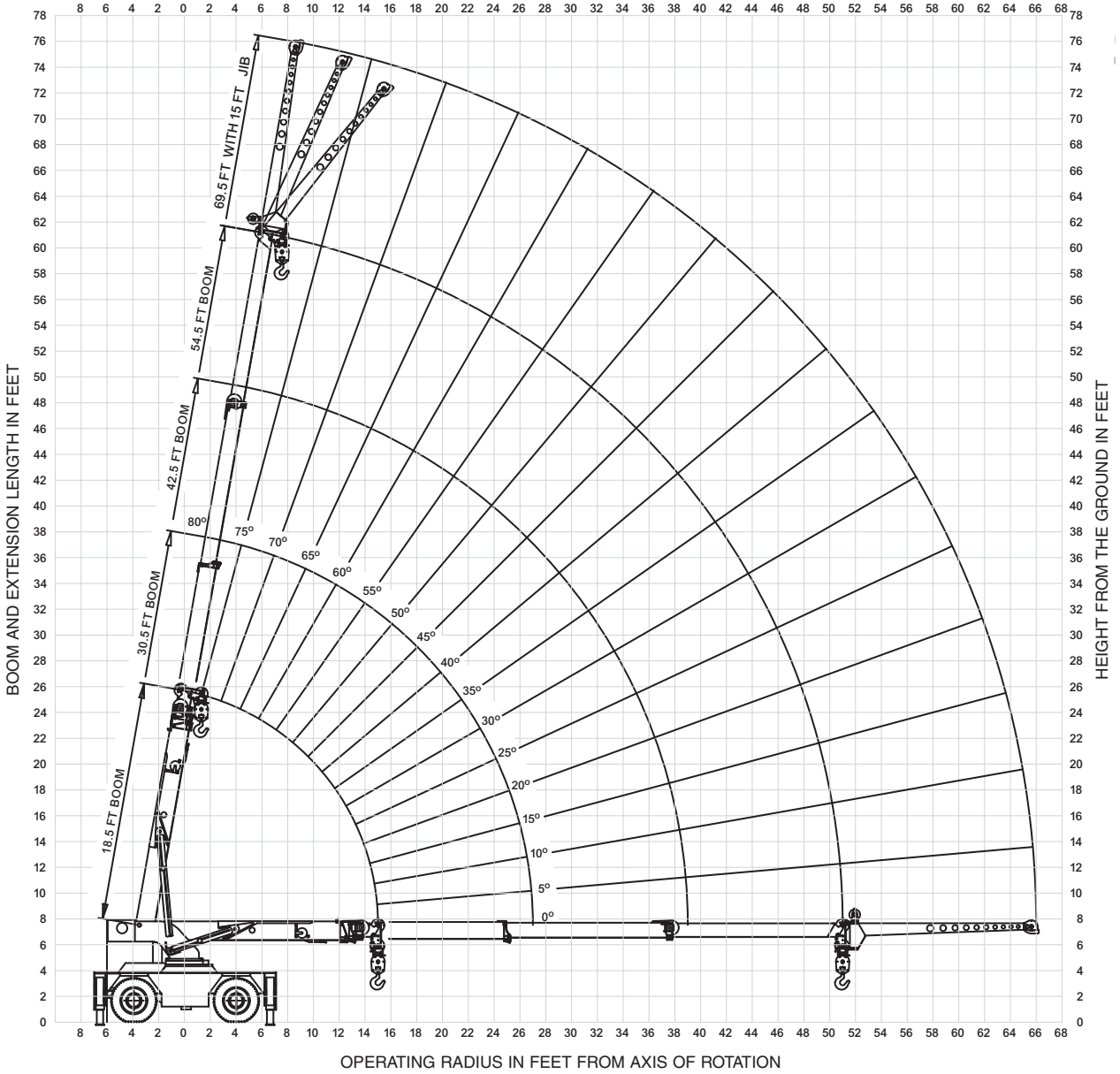

410 Stevenson Dr • Bolingbrook, IL 60440 • 630-972-9199
16675 Van Dam Rd • South Holland, IL 60473 • 219-972-9199

www.stevensoncrane.com

Shuttlelift Carrydeck Crane 5560B - Specs

5560B

MAIN BOOM LOAD RATINGS ON OUTRIGGERS Extended and Down 360° or Retracted and Down Front/Rear								
Radius (ft)	18.5 ft BOOM		30.5 ft BOOM		42.5 ft BOOM		54.5 ft BOOM	
	Boom Angle (deg)	Rated Load (lbs)	Boom Angle (deg)	Rated Load (lbs)	Boom Angle (deg)	Rated Load (lbs)	Boom Angle (deg)	Rated Load (lbs)
6	64	36000	75	24500	79	23700	-	-
8	57	31500	71	24500	77	23000	80	17400
10	49	24000	67	24000	74	21500	77	15800
12	39	19500	63	20000	71	19700	75	14000
14	25	16200	58	16800	68	17000	73	12600
15.0	0	15000	56	15500	66	15800	72	12000
16	-	-	53	14400	65	14600	71	11400
18	-	-	48	12500	62	12700	69	10500
20	-	-	43	11000	59	11200	66	9600
22	-	-	37	9800	55	10000	64	8900
24	-	-	29	8700	52	9000	61	8300
26	-	-	18	7800	48	8100	59	7700
27.0	-	-	0	7400	46	7700	58	7500
28	-	-	-	-	44	7300	56	7200
30	-	-	-	-	40	6500	54	6700
32	-	-	-	-	36	5700	51	6000
34	-	-	-	-	30	5100	48	5400
36	-	-	-	-	24	4500	45	4800
38	-	-	-	-	15	4000	42	4300
39.0	-	-	-	-	0	3900	41	4000
40	-	-	-	-	-	-	39	3800
42	-	-	-	-	-	-	35	3400
44	-	-	-	-	-	-	31	3100
46	-	-	-	-	-	-	27	2900
48	-	-	-	-	-	-	21	2700
51.0	-	-	-	-	-	-	0	2400

MAIN BOOM ON RUBBER		
Radius (ft)	Any Boom Length	
	Front Rating (lbs)	360° Rating (lbs)
6	16000	10900
8	13000	8700
10	11000	7400
12	9100	6400
14	7800	5600
15.0	7100	5300
16	6500	4900
18	5600	4200
20	4800	3500
22	4200	3000
24	3600	2500
26	3150	2200
27.0	2950	2050
28	2800	1900
30	2450	1650
32	2100	1400
34	1900	1200
36	1750	1000
38	1525	850
39.0	1450	775
40	1350	725
42	1150	625
44	1050	525
46	950	425
48	850	300
51.0	700	200

RATING REDUCTIONS FOR LOAD HANDLING DEVICES INSTALLED (lbs)		
	FROM MAIN BOOM	FROM JIB
MAIN BLOCK	230	NOT APPLICABLE
HOOK & BALL	100	100
JIB STOWED	NO REDUCTION	NOT APPLICABLE
JIB DEPLOYED	700	NO REDUCTION

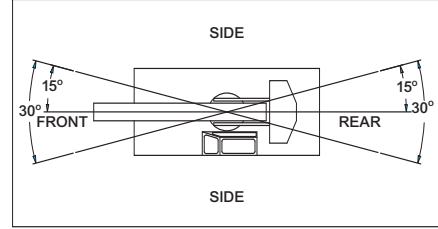

SHADED AREAS ARE GOVERNED BY STRUCTURAL STRENGTH, DO NOT RELY ON TIPPING.

OPERATION OF THIS EQUIPMENT IN EXCESS OF RATING CHARTS AND DISREGARD OF INSTRUCTIONS IS DANGEROUS AND VOIDS WARRANTY.

MAIN BOOM LOAD RATINGS ON OUTRIGGERS Retracted and Down 360°								
Radius (ft)	18.5 ft BOOM		30.5 ft BOOM		42.5 ft BOOM		54.5 ft BOOM	
	Boom Angle (deg)	Rated Load (lbs)	Boom Angle (deg)	Rated Load (lbs)	Boom Angle (deg)	Rated Load (lbs)	Boom Angle (deg)	Rated Load (lbs)
6	64	36000	75	24500	79	23700	-	-
8	57	29000	71	24500	77	23000	80	17400
10	49	16000	67	22000	74	20000	77	15800
12	39	11400	63	12900	71	12800	75	13000
14	25	8900	58	9900	68	10200	73	10600
15.0	0	8000	56	8900	66	9300	72	9500
16	-	-	53	8100	65	8500	71	8500
18	-	-	48	6800	62	7200	69	7200
20	-	-	43	5900	59	6200	66	6100
22	-	-	37	5000	55	5200	64	5300
24	-	-	29	4100	52	4500	61	4500
26	-	-	18	3600	48	3800	59	3900
27.0	-	-	0	3400	46	3600	58	3600
28	-	-	-	-	44	3300	56	3300
30	-	-	-	-	40	2900	54	2800
32	-	-	-	-	36	2500	51	2500
34	-	-	-	-	30	2200	48	2200
36	-	-	-	-	24	2000	45	2000
38	-	-	-	-	15	1800	42	1800
39.0	-	-	-	-	0	1700	41	1700
40	-	-	-	-	-	-	39	1600
42	-	-	-	-	-	-	35	1400
44	-	-	-	-	-	-	31	1300
46	-	-	-	-	-	-	27	1100
48	-	-	-	-	-	-	21	900
51.0	-	-	-	-	-	-	0	700

15 FT. JIB CAPACITIES ON EXTENDED OUTRIGGERS					
Main Boom Angle (deg)	Jib Offset Angle				
	0 deg		15 deg		30 deg
	To 42.5 ft Main Boom	To 54.5 ft Main Boom	To 42.5 ft Main Boom	To 54.5 ft Main Boom	Any Boom Length
80	-	-	5000	5000	3500
75	7500	-	4400	4400	3100
70	6100	-	3900	3900	2800
65	5000	4600	3500	3500	2550
60	4300	3800	3150	3150	2350
55	3800	3300	2850	2850	2200
50	3400	2900	2600	2600	2100
45	3050	2600	2400	2400	2000
40	2800	2400	2250	2250	1950
35	2600	2150	2150	2050	1900
30	2400	1930	2080	1850	1830
25	2300	1750	2050	1720	-
20	2200	1600	2000	1590	-
15	2100	1500	1950	1520	-
10	2050	1460	-	-	-
5	2020	1450	-	-	-
0	2000	1440	-	-	-

MAXIMUM PERMISSIBLE SINGLE LINE PULL = 9000 lbs

WIRE ROPE: 1/2 inch dia. 10 x 19 EIPS IWRC BRIGHT
Min. req'd breaking strength = 31,500 lbs

- The rated loads are the maximum lift capacities as determined by operating radius, boom length and boom angle. The operating radius is the horizontal distance from a projection of the axis of rotation to the supporting surface, before loading, to the center of vertical hoist line or tackle with load applied.
- The rated loads shown on outriggers do not exceed 85% of actual tipping. The rated loads shown on rubber do not exceed 75% of actual tipping. These ratings are based on freely suspended loads with the crane leveled, standing on a firm, uniform supporting surface. Practical working loads depend on supporting surface, operating radius and other factors affecting stability. Hazardous surroundings, climatic conditions, experience of personnel and proper handling must all be taken into account by the operator.
- The weights of all load handling devices, such as hooks, hook blocks, slings, etc., except the hoist rope, shall be considered as part of the load. See above.
- Ratings on outriggers are for either outriggers fully extended and down or fully retracted and down. Ratings for outriggers fully retracted and down will apply for any intermediate outrigger setting.
- Ratings on rubber depend on tire capacity, condition of tires and proper inflation pressure (120 psi). Loads on rubber may be transported at a maximum speed of 2.5 mph on a smooth hard level surface with boom retracted to the shortest length possible and centered over front. Do not use jib with crane on rubber.
- For operating radius not shown, use load rating of next larger radius.
- The maximum combined total boom and deck load is 16,000 lbs. The maximum deck load only is 20,000 lbs.
- Do not induce any external side loads to boom or jib.

