

# Shuttlelift Carrydeck Crane 5540F - 3 section boom - Specs

## 5540F

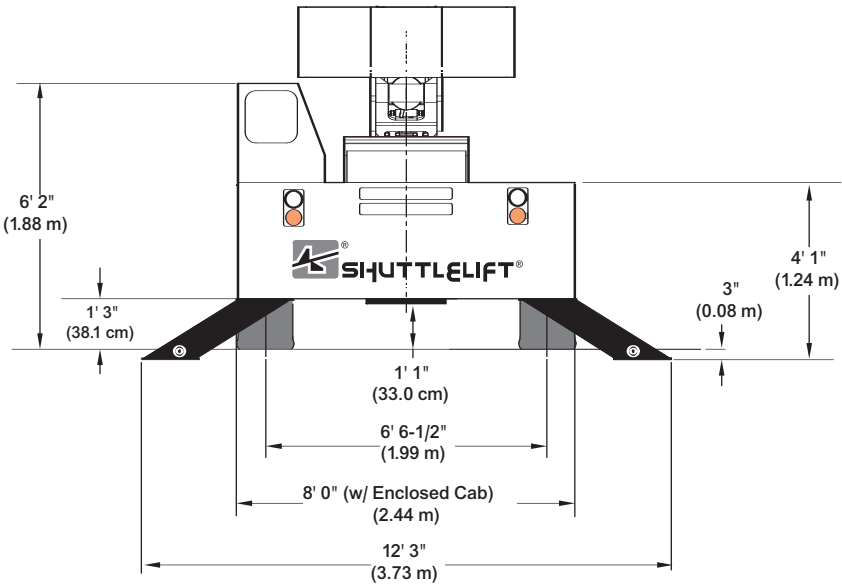
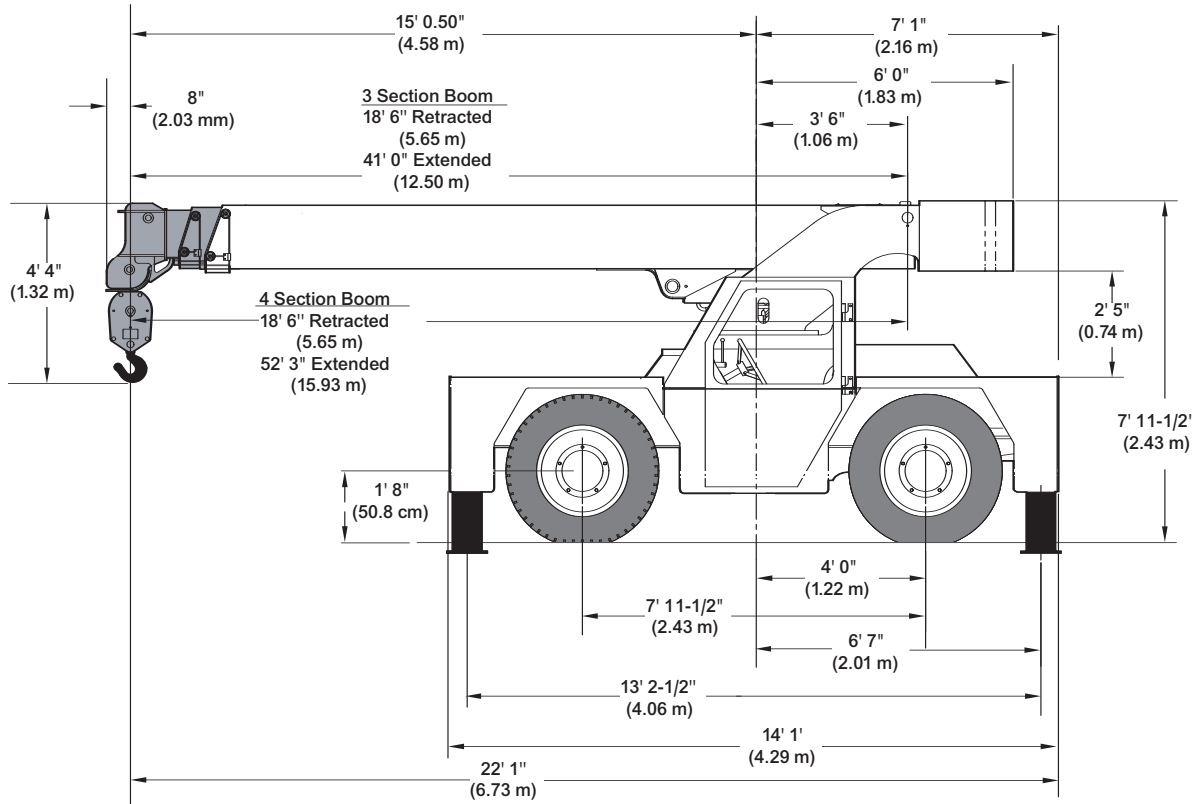

410 Stevenson Dr • Bolingbrook, IL 60440 • 630-972-9199  
16675 Van Dam Rd • South Holland, IL 60473 • 219-972-9199

[www.stevensoncrane.com](http://www.stevensoncrane.com)

# Shuttlelift Carrydeck Crane 5540F - 3 section boom - Specs

## 3-SECTION BOOM

# 5540F

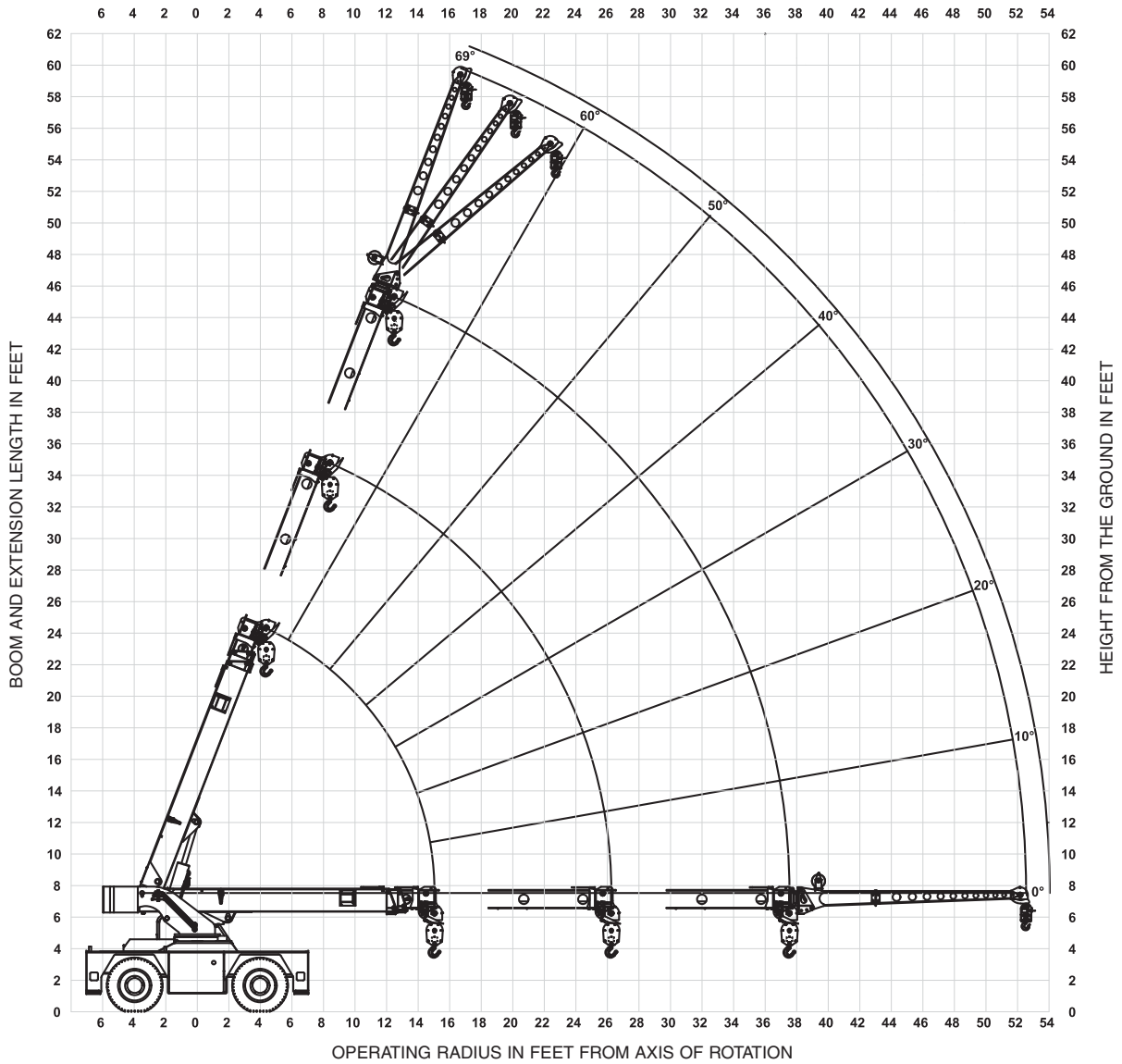

410 Stevenson Dr • Bolingbrook, IL 60440 • 630-972-9199  
 16675 Van Dam Rd • South Holland, IL 60473 • 219-972-9199

[www.stevensoncrane.com](http://www.stevensoncrane.com)

# Shuttlelift Carrydeck Crane 5540F - 3 section boom - Specs

## 5540F w/3-section boom

	RADIUS (ft)	ON OUTRIGGERS (lbs)		ON RUBBER (lbs)	
		F/R	360°	F/R	360°
MAIN BOOM	6.0	30000	30000	17000	17000
	8.0	26200	26200	13500	14600
	10.0	22300	22300	10700	10880
	12.0	18600	18600	8710	8100
	14.0	14800	14800	7210	6000
	15.0	13000	13000	6600	5250
	16.0	12200	12200	6060	4760
	18.0	10800	10800	5120	3900
	20.0	9630	9180	4370	3190
	22.0	8640	7480	3710	2660
	24.0	7790	6210	3070	2200
	26.0	7040	5310	2620	1820
	28.0	6420	4740	2260	1530
	30.0	5700	4290	1990	1320
	32.0	5060	3920	1790	1160
	34.0	4510	3580	1610	1040
	36.0	4020	3260	1460	930
	37.5	3700	3060	1370	860
	JIB	40.0	3480	2860	1270
42.0		3310	2700	1190	740
44.0		3130	2560	1120	690
46.0		2960	2410	1040	640
48.8		2710	2210	930	570
52.5		2390	1940	790	480

MAIN BOOM ANGLE (deg)	JIB STRUCTURAL CAPACITIES (lbs)		
	0°	15°	30°
69	6000	3900	2800
65	5000	3500	2550
60	4300	3150	2350
55	3800	2850	2200
50	3400	2600	2100
45	3050	2400	2000
40	2800	2250	1950
35	2600	2150	1900
30	2400	2080	1850
25	2300	2050	-
20	2200	2000	-
15	2100	1950	-
10	2050	-	-
5	2020	-	-
0	2000	-	-

JIB CAPACITY IS LIMITED BY BOTH STRUCTURAL CAPACITY CHART AND MAIN CAPACITY CHART.

SHADED AREAS ARE GOVERNED BY STRUCTURAL STRENGTH, DO NOT RELY ON TIPPING.

OPERATION OF THIS EQUIPMENT IN EXCESS OF RATING CHARTS AND DISREGARD OF INSTRUCTIONS IS DANGEROUS AND VOIDS WARRANTY.

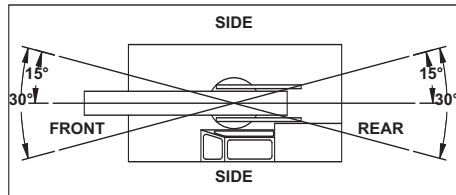

REDUCTION CHART		
	FROM MAIN BOOM RATINGS	FROM JIB RATINGS
MAIN BLOCK	210 lbs	N/A
HOOK & BALL	100 lbs	100 lbs
JIB, STOWED	0 lbs	N/A
JIB, DEPLOYED	700 lbs	0 lbs

RIGGING CHART	
<p>1-PART 0-7500 lbs</p>	<p>4-PART 0-30000 lbs</p>
<p>WIRE ROPE: 1/2 inch diameter Min. breaking strength 26250 lbs.</p>	

- The rated loads are the maximum lifting capacities as determined by operating radius only. Any combination of boom lengths and angles may be used to obtain operating radius. The operating radius is the horizontal distance from a projection of the axis of rotation to the supporting surface, before loading, to the center of vertical hoist line or tackle with load applied.
- The rated loads shown on outriggers do not exceed 85% of actual tipping. The rated loads shown on rubber do not exceed 75% of actual tipping. These ratings are based on freely suspended loads with the crane leveled, standing on a firm, uniform supporting surface. Practical working loads depend on supporting surface, operating radius and other factors affecting stability. Hazardous surroundings, climatic conditions, experience of operator and proper training must be taken into account by the operator.
- The weights of all load handling devices, such as hooks, hook blocks, slings, etc., except the hoist rope, shall be considered as part of the load. See reduction chart.
- Ratings on outriggers are with outriggers fully extended.
- Ratings on rubber depend on tire capacity, condition of tires and proper inflation pressure (120 psi). Loads on rubber may be transported at a maximum speed of 2.5 mph on a smooth, hard, level surface with the boom retracted to the shortest length possible and centered over the front.
- For operating radius not shown, use load rating of next larger radius.
- The maximum combined total boom and deck load is 16000 lbs. The maximum deck load only is 20000 lbs.
- Do not induce any external side loads to boom or jib.



410 Stevenson Dr • Bolingbrook, IL 60440 • 630-972-9199  
16675 Van Dam Rd • South Holland, IL 60473 • 219-972-9199

[www.stevensoncrane.com](http://www.stevensoncrane.com)